

FEIDER

MACHINES



PETROL BLOWER

FSDT75

USER GUIDE

CAUTION : Read the instructions before using the machine !

CONTENTS

1. SAFETY INSTRUCTIONS.....	3
2. TECHNICAL SPECIFICATIONS.....	7
3. DESCRIPTION.....	8
4. ASSEMBLY.....	9
5. FILLING THE FUEL AND OIL TANK.....	10
6. OPERATION.....	11
7. MAINTENANCE AND STORAGE.....	16
8. DECLARATION OF CONFORMITY.....	21
9. WARRANTY.....	22
10. PRODUCT FAILURE.....	23
11. WARRANTY EXCLUSIONS.....	24

1. SAFETY INSTRUCTIONS

WARNING: For your own safety, please read this manual before attempting to operate your new unit. Failure to follow instructions can result in serious personal injury. Spend a few moments to familiarize yourself with your blower before each use. If you give this tool to another person, also hand over this manual.

Use this tool as described in this manual. Any mishandling and any use contrary to the instructions will not in any way engage the liability of the manufacturer.

Non-compliance with safety instructions and use can cause a risk of electric shock, fire and /or injury to persons.

READ YOUR USER MANUAL THOROUGHLY BEFORE OPERATING YOUR UNIT.

- This appliance is not intended for use by persons (including children) with reduced physical, sensory or mental capabilities, or lack of experience and knowledge, unless they have been given supervision or instruction concerning use of the appliance by a person responsible for their safety.
- Children should be supervised to ensure that they do not play with the appliance.
- Never allow children, persons with reduced physical, sensory or mental capabilities or lack of experience and knowledge or people unfamiliar with these instructions to use the machine, local regulations may restrict the age of the operator.
- Never use the machine when people, especially children, or pets are nearby.
- Remember that the operator or user is responsible for accidents or hazards occurring to persons or their belongings.
- Do not disassemble the tool yourself. Disassembly, repair or verification must be made exclusively by qualified personnel.
- **WEAR CLOSE FITTING, TOUGH WORK CLOTHING** that will provide protection, such as long slacks or trousers, safety work shoes, heavy duty work gloves, hard hat, a safety face shield, or safety glasses for eye protection. The tool is extremely noisy and requires the use of ear protection, such as a good grade of ear plugs or other sound barriers.
- Always carry the machine by its handle; never use any other part of the machine.
- **REFUEL IN A SAFE PLACE.** Open fuel cap slowly to release any pressure which may have formed in fuel tank. Always wipe unit of fuel or oil spills before starting. To prevent a fire hazard, move at least 10 feet (3meters) from fueling area before starting.
- **TURN UNIT OFF** before setting it down and also before installing or removing attachments.
- **KEEP ALL SCREWS AND FASTENERS TIGHT** and the unit in good operating condition. Never operate this equipment if it is improperly adjusted or not completely and securely assembled.
- **KEEP HANDLES DRY**, clean and free of fuel mixture.
- **STORE EQUIPMENT AWAY FROM POSSIBLE IGNITION SOURCES**, such as gas-powered water heaters, clothes dryers, or oil-fired furnaces, portable heaters, etc.
- **ALWAYS KEEP** the engine free of debris build-up.
- **OPERATION OF EQUIPMENT** should always be restricted to mature and properly instructed individuals.
- **ALL PERSONS WITH RESPIRATORY PROBLEMS** and persons operating blower in very dusty environments, should wear a dust particle mask at all times. Paper dust masks are available at most paint and hardware stores.
- Operate the machine only at reasonable hours - not early in the morning or late at night when people might be disturbed. Comply with times listed in local ordinances.
- Avoid using the machine in bad weather, especially when there is a risk of thunderstorms and lightning.
- In case of accident, immediately stop using the machine. Turn the machine off and check the

problem. Do not use the machine while the machine is damaged.

- If the machine should start making any unusual noise or vibration, immediately shut off the power source and allow the machine to stop. Take the following steps before restarting and operating the machine:
 - a) Inspect for damage;
 - b) Replace or repair any damaged parts;
 - c) Check for and tighten any loose parts.
- If the machine becomes clogged, shut-off the power source before cleaning debris.
- Never operate the machine with defective guards or shields, or without safety devices in place.
- Keep the power source clean of debris and other accumulations to prevent damage to the power source or possible fire.
- Do not carry this machine while it is in operation. Always switch off the tool and always transport it by its handle and in order to avoid accidents and a fuel leak.
- Stop the machine and make sure that all moving parts have come to a complete stop
 - a) Whenever you leave the machine;
 - b) Before clearing blockages or unclogging chute;
 - c) Before checking, cleaning or working on the machine.
- Do not tilt the machine while the power source is running.
- Operate the machine at the lowest possible engine speed to do the job. Like this, vibration and noise levels as well as the tool's wear can be kept to a minimum.
- Use rakes and brooms to loosen debris before blowing.
- In dusty conditions, slightly dampen surfaces.
- Use the full blower nozzle extension so the air stream can work close to the ground.
- Watch out for children, pets, open windows etc. and blow debris safety away.
- **WARNING: DO NOT USE ANY OTHER FUEL** than that recommended in your manual. Always follow instructions in the Fuel and Lubrication section of this manual. Never use gasoline unless it is properly mixed with 2-cycle engine lubricant. Permanent damage to engine will result, voiding manufacturer's warranty.
- **DO NOT SMOKE** while refueling or operating equipment.
- **DO NOT OPERATE UNIT WITHOUT A MUFFLER** and properly installed muffler shield.
- **DO NOT TOUCH** or let your hands or body come in contact with a hot muffler or spark plug wire.
- **DUE TO THE DANGER** of exhaust fumes, never operate blower in a confined or poorly ventilated area.
- **NEVER POINT BLOWER** in the direction of people, animals, buildings, automobiles, or open windows, etc.
- **DO NOT** operate unit without inlet cover installed to prevent contact with impeller.
- **DO NOT** set a hot engine down where flammable material is present.
- **DO NOT OPERATE UNIT FOR PROLONGED PERIODS.** Rest periodically to prevent damage from vibration, damage to ears or damage to the appliance.
- Operate the machine in a recommended position and only on a firm, level surface.
- Do not operate the machine on a paved or gravel surface where ejected material could cause injury.

WARNING: DO NOT ADD, REMOVE OR ALTER ANY COMPONENTS OF THIS PRODUCT. Doing so could cause personal injury and/or damage the unit, voiding the manufacturer's warranty.

- **DO NOT OPERATE UNIT WHILE TIRED, SICK OR UNDER THE INFLUENCE OF ALCOHOL OR DRUGS.**
- **DO NOT** operate your unit near or around flammable liquids or gases whether in or out of doors. An explosion and/or fire may result.

- DO NOT WEAR loose clothing, scarfs, neck chains, unconfined long hair, and the like. Doing so could cause injury associated with objects being drawn into the rotating parts.
 - DO NOT refuel a running engine or an engine that is hot.
 - Before using, always visually inspect to see that fasteners are secure, the housing is undamaged and that guards and screens are in place. Replace worn or damaged components in sets to preserve balance. Replace damaged or unreadable labels.
 - Before starting the machine, make certain that the tube is empty.
 - Keep your face and body away from the nozzle.
 - Do not allow hands or any other part of the body or clothing inside the discharge chute or near any moving part.
 - Keep proper balance and footing at all times. Do not overreach. Never stand at a higher level than the base of the machine when blowing material with it.
 - Always stand clear of the discharge zone when operating this machine.
- To reduce the risk of hearing loss associated with sound level, hearing protection is required.
 - To reduce the risk of injury associated with contacting rotating parts, stop the engine before installing or removing attachments. Do not operate without guard in place. Always disconnect the spark plug before performing maintenance or accessing any movable parts.
 - Do not point the blower nozzle in the direction of people or pets.
 - Never run the unit without the proper equipment attached. When used as a blower, always install the blower tubes.
 - operate the machine only at reasonable hours – not early in the morning or late at night when people might be disturbed;
 - Do not to operate the machine near open windows.
 - use rakes and brooms to loosen debris before blowing
 - slightly dampen surfaces in dusty conditions or use mister attachment;
 - Limit the time of use of the tool. Take a time of rest between 2 operations. Do not work earlier or later in the night. Do be exposed to noise and vibration for a prolonged time. Noise can bring damage to the ears.
 - This machine is extremely noisy. Always wear a hearing protection when use the tool.
 - In the event of accident or breakdown, stop to use the machine. Switch off the tool and wait until it completely stops. Check the problem. In case of blockage, clear the blockage carefully. In case of breakdown, bring the tool to an after sales service for inspection and reparation. Only use the tool when it is safely unblocked.
 - operate the machine only at reasonable hours – not early in the morning or late at night when people might be disturbed;
 - WARNING – there is danger from rotating parts; do not enter in contact with them.

Maintenance and storage

When the machine is stopped for servicing, inspection, or storage, or to change an accessory, shut off the power source and make sure that all moving parts have come to a complete stop. Allow the machine to cool before making any inspections, adjustments, etc. Maintain the machine with care and keep it clean.

- Store the machine in a dry place out of the reach of children.
- Always allow the machine to cool before storing.
- Replace worn or damaged parts for safety. Use only genuine replacement parts and accessories.
- Never attempt to override the interlocked feature of the guard.







Residuals risks

Even if you use this product in compliance with all safety requirements, potential risks of injury and damage remain. The following hazards may arise from the structure and design of this product.

Always be vigilant when using this product, so you can recognize and manage the risks early. Rapid intervention can prevent serious injury and property damage. Turn off the tool if there are any malfunctions. Have it checked by a qualified professional and have repairs carried out, if necessary, before using it again.

- There are harmful health consequences resulting from the emission of vibrations if the product is used for long periods of time or not properly managed and properly maintained.
- There is risk of injury and property damage due to attachments or broken the sudden impact of hidden objects.
- Risk of injury to persons and property caused by flying objects.
- Prolonged use of this product exposes the operator to vibration and can produce so-called "white finger" disease. To reduce the risk, wear gloves and keep your hands warm.
- If any of the symptoms of "white finger syndrome" occur, seek immediate medical attention. Symptoms of the "white finger" include numbness, loss of sensitivity, tingling, tingling, and pain, loss of strength, color changes or skin condition. These symptoms usually appear on the fingers, hands or wrists. Risk increases at low temperatures.
- Inhalation of particles of material blown.
- Unattended projections.
- Contact with foreign objects.
- Contact with the tool in operation.
- Hearing loss in the absence of correct hearing protection.

Symbols

	Read instruction handbook.
	Risk of projection, keep bystanders away.
	Wear ocular protection and hearing protection.
	Guarantee sound power level.
	Risk of fire.
	Hot surface.
	Risk of inhalation of exhausted gas.

Intended use

- This blower is meant to be used for blowing leaves, dust or garden debris into a desired direction. It must not be used for blowing water, chemical products, flammable material, metal or wood and other dangerous objects.
- This product is intended for private domestic use only. It must be used outdoors.
- This product is not intended to be used in a closed room and places where exhausted gas and flames can be present.
- The use of this product in case of rain or humid environments is prohibited.
- Any other use might lead to damage of the appliance, property or personal injury.

2. TECHNICAL SPECIFICATIONS

Model:	FSDT75
Input power	2,2 kW
Maximum engine speed	7000/min
Idling speed	3000/min
Engine displacement	75.6 cm ³
Engine type	Air cooled, 4-stroke, single cylinder
Fuel tank capacity	1900 cm ³
Engine oil	SAE 10W-30 oil (automobile 4-stroke engine oil)
Engine oil volume	220 cm ³
Carburetor	Diaphragm type
Spark plug	CMR7H
Electrode gap	0.028" - 0.031" (0.7 mm - 0.8 mm)
Air speed	210km/h
Air volume	1120m ³ /h
Measured sound power level LPA	110,3 dB(A) K= 3 dB(A)
Measured sound pressure level LWA	93,3 dB(A) K= 3 dB(A)
Guarantee sound power level	116 dB(A)
Vibration	Max 4,681 m/s ² K= 1,5 m/s ²

3. DESCRIPTION

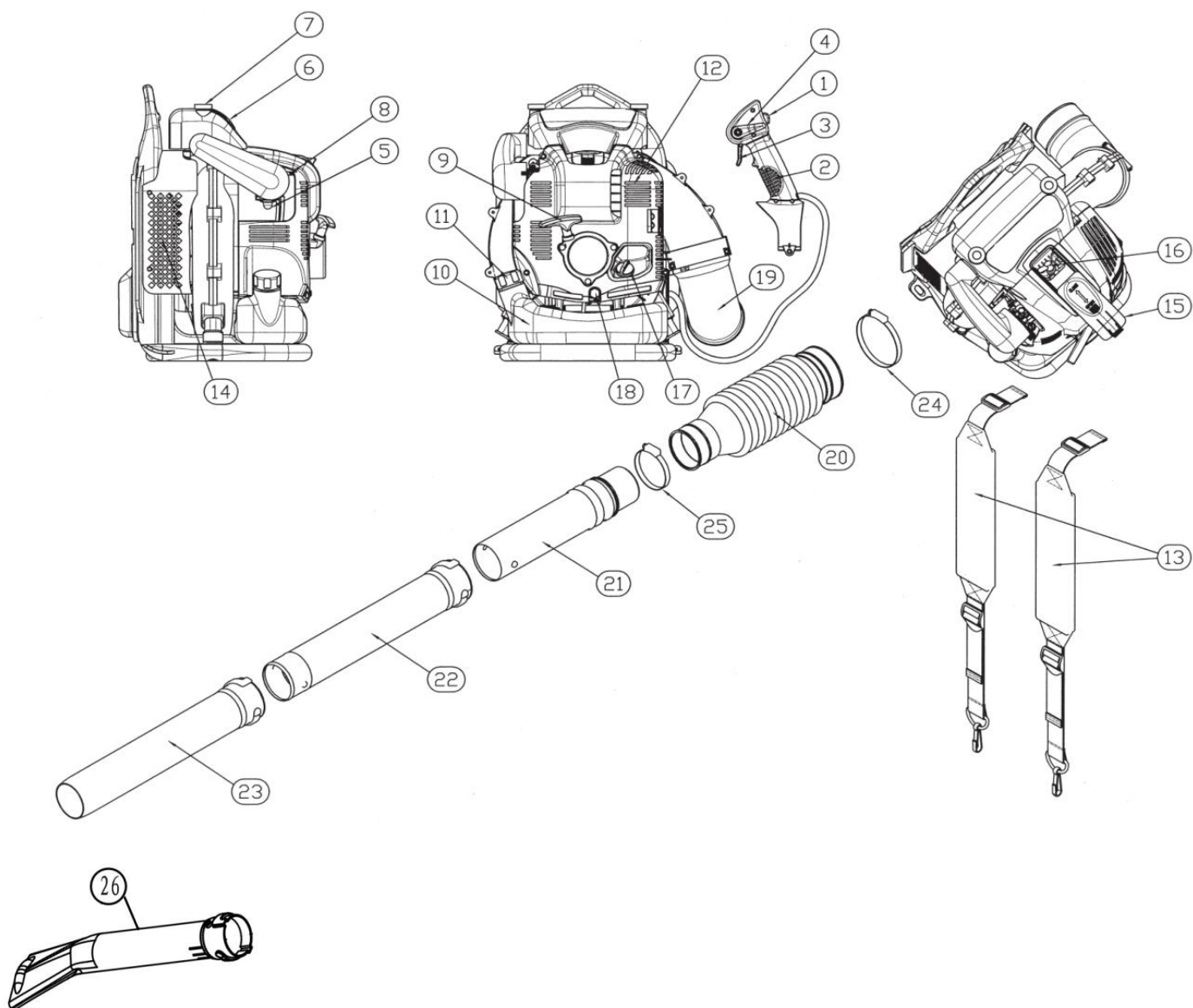

1	Stop switch	10	Fuel tank	19	Elbow
2	Control handle	11	Fuel tank cap	20	Flexible pipe
3	Throttle trigger	12	Muffler	21	Swivel pipe
4	Stop control lever	13	Shoulder strap	22	Long pipe 1
5	Primer pump	14	Air inlet screen	23	Long pipe 2
6	Air cleaner cover	15	Spark plug cover	24	Hose band
7	Knob bolt(of air cleaner cover)	16	Spark plug	25	Hose band
8	Throttle lever	17	Oil cap	26	Flat nozzle tube
9	Starter rope	18	Oil drain bolt		

4. ASSEMBLY

▲CAUTION: Before performing any work on the blower, always stop the engine and pull the spark plug cap off the spark plug.

▲CAUTION: Start the blower only after having assembled it completely.

CAUTION: Always wear protective gloves.

Assembling blower pipes

1. Insert the swivel pipe into the flexible pipe and tighten them with the hose band.

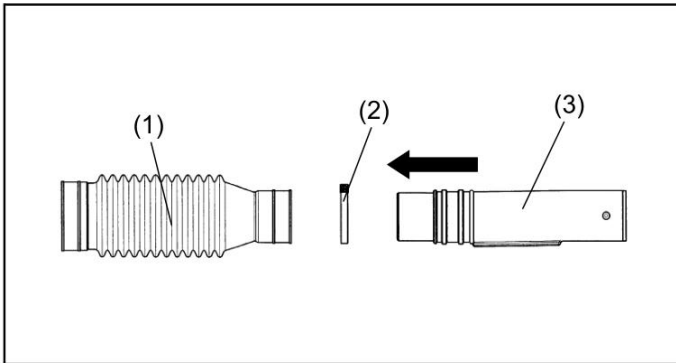

► (1). Flexible pipe (2). Hose band (3). Swivel pipe

2. Install the control handle / handle assembly (4) onto the swivel pipe and tighten them with the clamp screw (5).

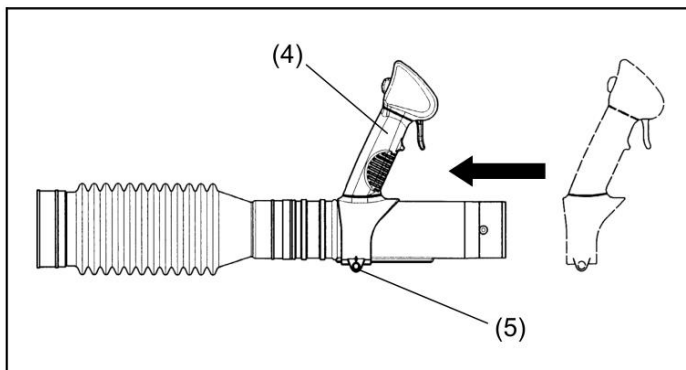

► (4). Control handle / handle assembly (5). Clamp screw

3. Attach the flexible pipe to the elbow

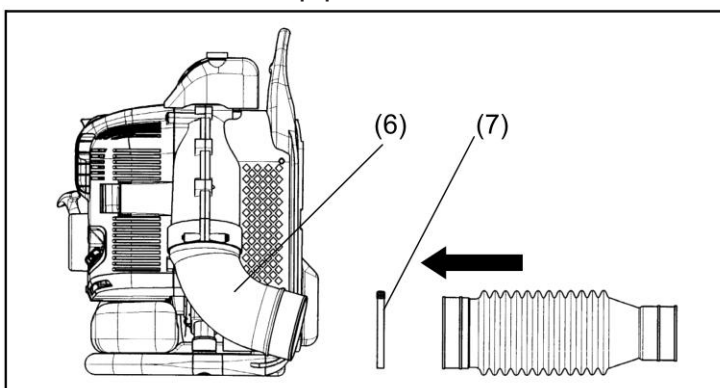

► (6). Elbow (7). Hose band

4. Attach long pipe 1 to the swivel pipe, Turn it clockwise to lock it in place. Then attach the second long pipe, Turn it clockwise to lock it in place.

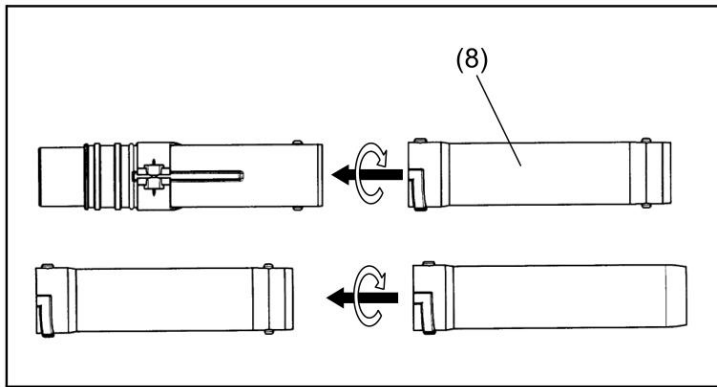

5. FILLING THE FUEL AND OIL TANK

1) Fuel tank

WARNING: When filling the tank:

- The tool should always be stopped and cooled.
- Never smoke during refueling. It must not have flames or sparks near the fuel
- Do not attempt to refuel when the engine is hot.
- If fuel has been spilled, immediately stop refueling and do not start the engine. Clean up the spill and fill the machine in another location.
- Do not refuel in a closed and unventilated area.

Always use unleaded with the tool, Do not use fuel containing ethanol or methanol.

Unleaded gasoline is a quality gasoline type, This will help to avoid damaging the fuel lines of the engine and other engine parts.

a. Filling the fuel tank

- Unscrew the fuel tank cap and remove it.
- Fill the tank slowly with the mixture. Do not exceed the maximum capacity(fill to 80% of its capacity preferably).
- Refit the cap on the fuel tank and tighten it.
- Wipe any spillage around the unit if necessary.

b. Storage of fuel

- The fuel must be kept in a clean and safe container and always closed.
- If you are not using the product for a long time, remove the fuel and add it to a container.
- Do not leave the fuel for a long time in the product. The fuel may clog the carburetor and the engine will not operate properly.

c. Disposal of fuel

When the fuel is no longer used or worn, please dispose of it in an authorized location.

Check local laws regarding disposal of fuels.

2) Oil tank

- Unscrew the oil tank
- Fill the tank, Do not overfill.
- Refit the cap on the tank, Wipe any spillage if necessary.

6. OPERATION

Starting the engine

▲WARNING: Never attempt engine start in a place where the fuel has been supplied. It may cause ignition or fire. When starting the engine, keep a distance of at least 3 meters from fuelling place.

▲WARNING: Exhaust gas from the engine is toxic. Do not operate the engine in a poorly-ventilated place, such as in a tunnel, building, etc. Operating the engine in the poorly-ventilated place may cause poisoning by exhaust gas.

▲WARNING: In case of detection of any abnormality in sound, odor, vibration after starting, stop the engine immediately and carry out inspection. If the engine is operated without attending such abnormality, an accident may occur.

▲WARNING: Do not touch hot engine cover. Otherwise skin burn may result.

WARNING: Make sure that there is no fuel leakage before starting the engine.

WARNING: Make sure that the engine stops when the stop switch is set to "O" position.

When the engine is cold or after refueling (cold start)

1. Put the blower on a flat surface.
2. Set the stop control lever to "I" position.

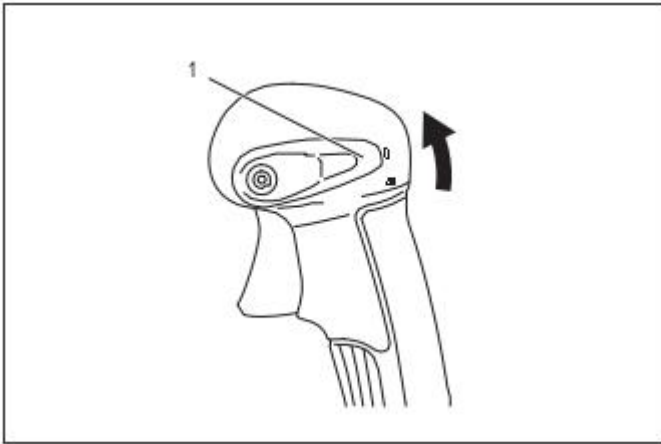

► 1. Stop control lever

3. Continue to push the primer pump until fuel comes into the primer pump.

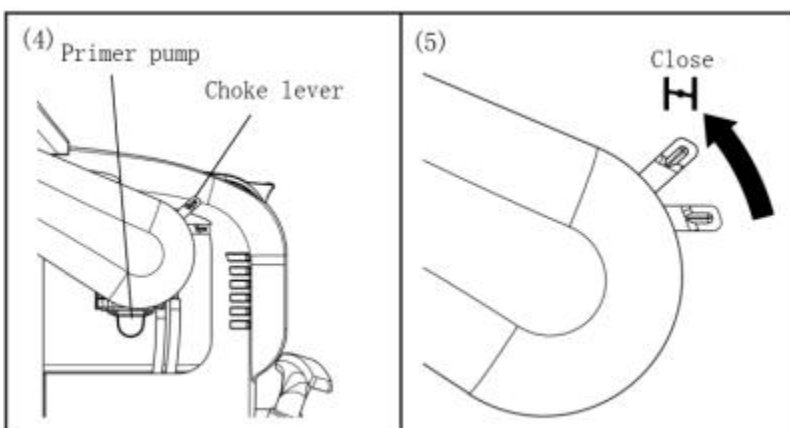

► (4). Primer pump (5). Choke lever

NOTE: In general, fuel comes into the carburetor by 7 to 10 pushes.

NOTE: Even the primer pump is pushed excessively, an excess of gasoline returns to the fuel tank.

4. Lift the choke lever to the closed position.
5. Pull out slowly the starter handle till feeling compression. Then pull it strongly.

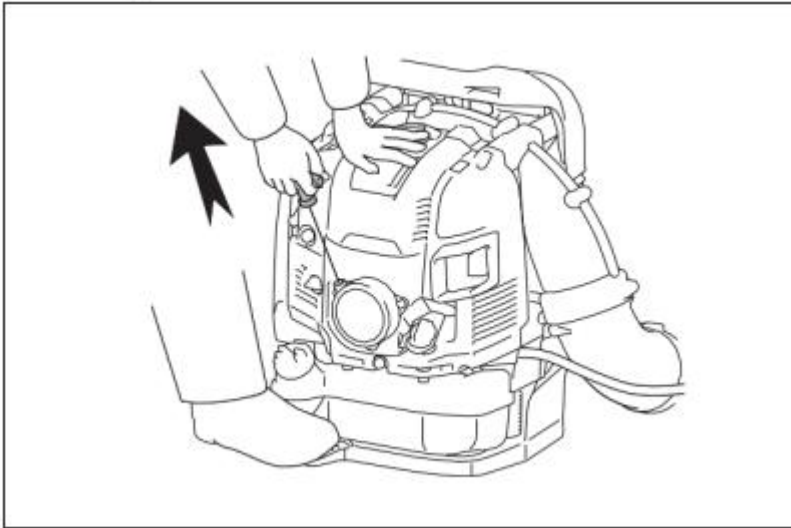

NOTICE: Never pull the rope to the full extension.

NOTICE: Return the starter knob gently into the housing. Otherwise released starter knob may hit your body or it may not rewind appropriately.

- When the engine starts, down the choke lever to open position.

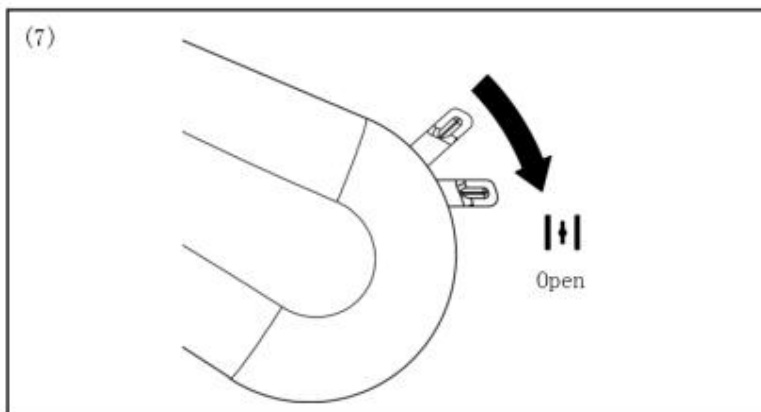

- 1. Throttle trigger 2. Stop control lever

Transporting the blower

CAUTION: When transporting the blower, be sure to stop the engine.

NOTE: Open the choke lever fully before pulling the throttle.

NOTE: In cold temperature or when the engine is not warm enough, never open the choke lever suddenly. Otherwise, the engine may stop.

- Warm-up for 2 to 3 minutes with engine speed idle or low.
- Warm-up is complete when quick engine acceleration from low rpm to full throttle is felt.

NOTE: If the operator keeps pulling the starter handle several times with the choke lever left in the “CLOSE” position, the engine may be difficult to start because of flooding of the fuel. In case of flooding of the fuel, remove the spark plug and pull the handle several times rapidly to discharge any excess fuel. Dry the spark plug electrode.

When the engine is warm (warm start)

- Put the blower on a flat surface.
- Push the primer pump several times.
- Make sure that the choke lever is open.
- Stomp the pedal with your right foot, and hold the top of the unit cover with left hand to prevent the engine from moving.
- Pull out slowly the starter handle till feeling compression. Then pull it strongly.
- When the engine is difficult to start, open the throttle by about 1/3.

Stopping the engine

For tube throttle model: Release the throttle trigger and then set the stop control lever to “O” position.

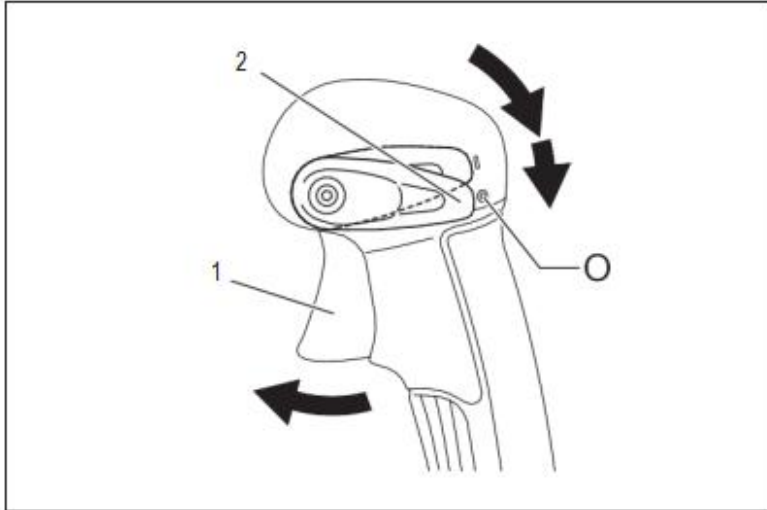

► 1. Throttle trigger 2. Stop control lever

Adjusting shoulder strap

1. Adjust the shoulder strap to a length that is comfortable to work while carrying the blower. To fasten the strap, pull the end of the strap downwards.

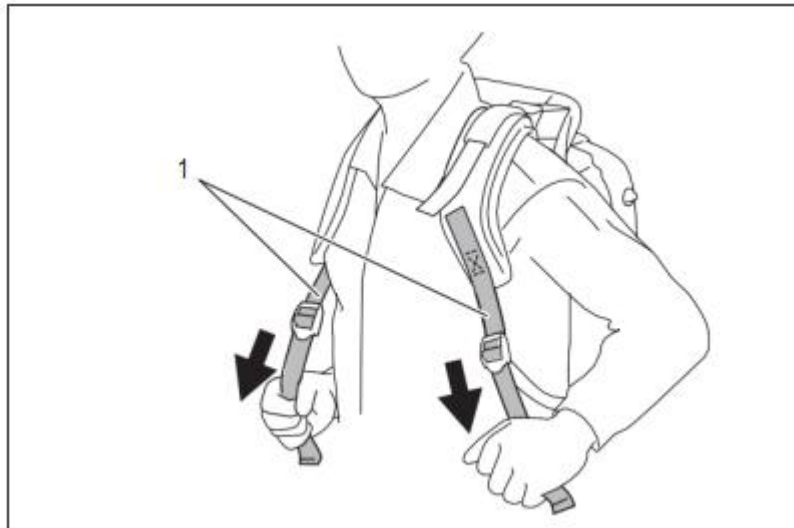

► 1. Shoulder strap

To loosen the strap, pull up the end of the fastener.

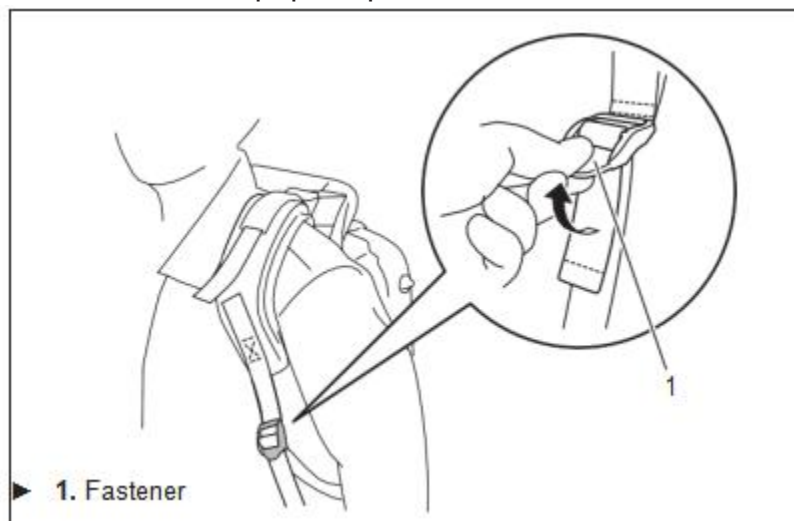

► 1. Fastener

2. Pull the stabilizer strap until there are no space left between your back and the blower housing. To fasten the strap, pull the end of the strap downwards.

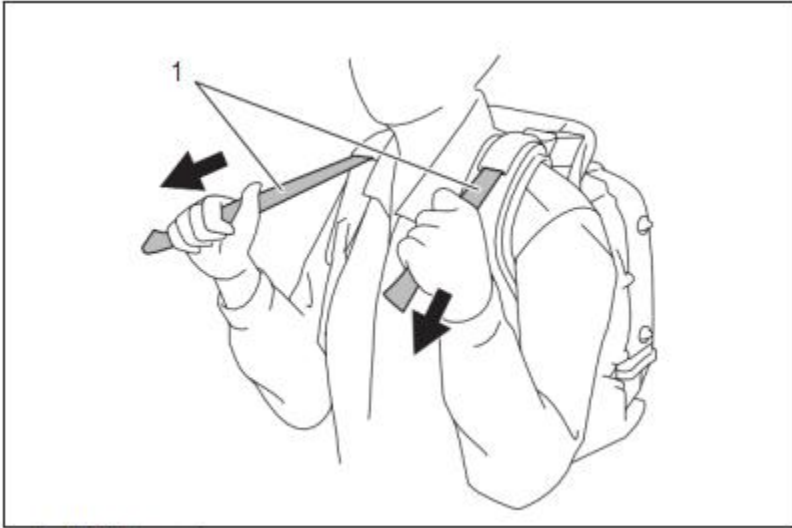

► 1. Stabilizer strap

To loosen the strap, pull up the end of the fastener.

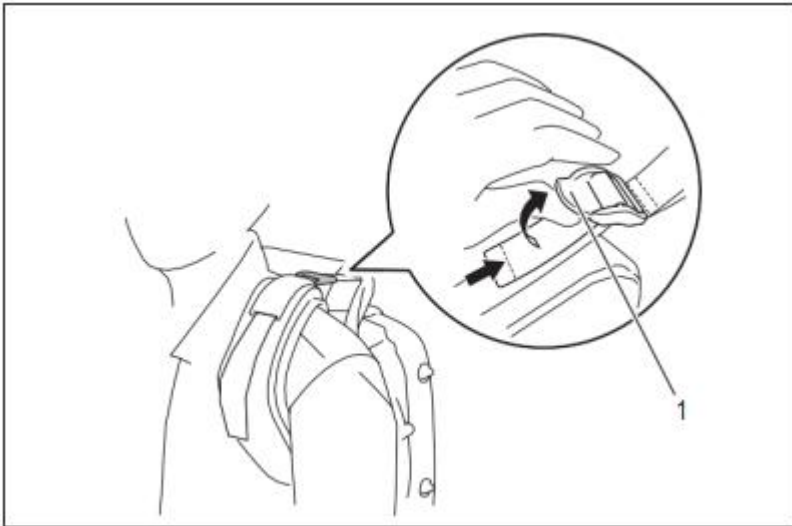

► 1. Fastener

Hip belt

Optional accessory

The hip belt enables the operator to carry the tool more stably

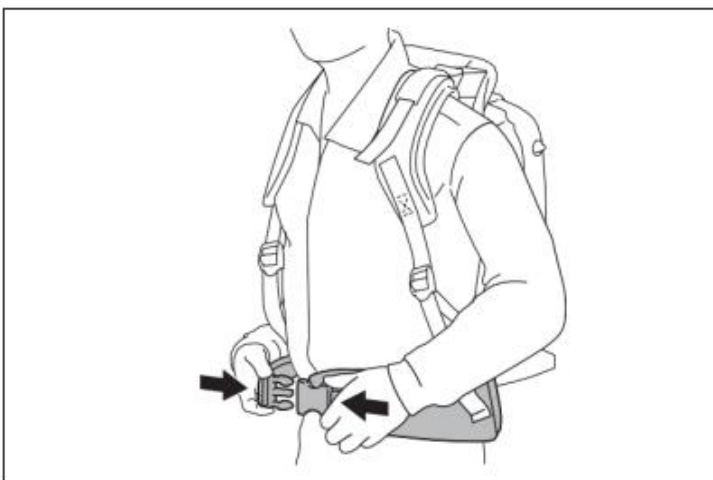

Adjusting the control lever position

For tube throttle model: Move the control handle along the swivel pipe to the most comfortable position. Then tighten the control handle with the screw

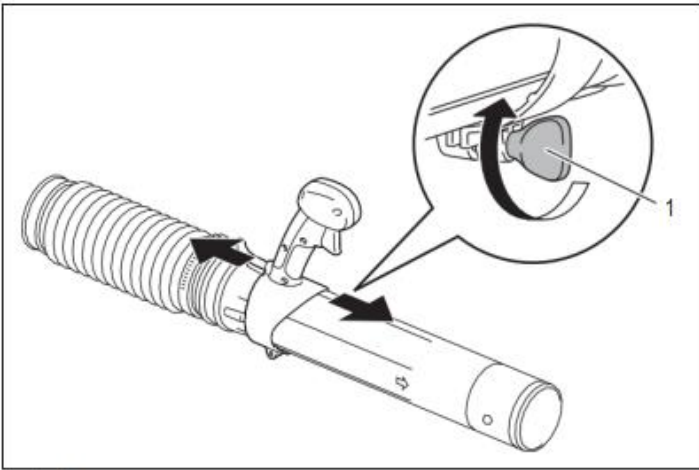

► 1. Screw

Blower Operation



1. While operating the blower, adjust the throttle trigger so that the wind force is appropriate for the work location and conditions.

2. Adjusting engine speed.

For tube throttle model: Engine speed increases by pulling the throttle trigger. To decrease the engine speed, loosen the throttle trigger.

The cruise control function allows the operator to maintain a constant engine speed without pulling the trigger lever. To increase the engine speed, turn the stop control lever to high speed. To decrease the engine speed, turn the stop control lever to low speed.

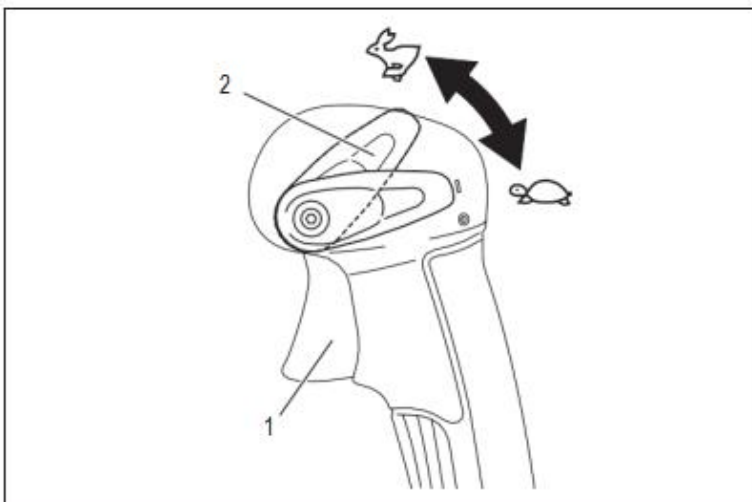

► 1. Throttle trigger 2. Stop control lever

Transporting the blower

CAUTION: When transporting the blower, be sure to stop the engine.

NOTICE: Do not sit or stand on the blower nor put a heavy object on it. It may damage the machine.

NOTICE: Maintain the blower in an upright position whenever transporting or storing. Transporting or storing in a position that is not upright may cause oil to spill inside the blower engine. This may result in oil leaks and white smoke from burning oil, and the air cleaner may become dirty with oil.

NOTICE: Do not drag the blower when transporting. Otherwise the blower housing may be damaged.

7. MAINTENANCE AND STORAGE

CAUTION: Before inspection and maintenance, stop the engine and allow it to cool down. Remove the spark plug and plug cap. Otherwise the operator may suffer burn or serious injury due to an accidental start-up.

CAUTION: After inspection and maintenance, make sure that all parts are assembled.

Replacing engine oil

CAUTION: The engine main unit and engine oil still remain hot just after the engine is stopped. When replacing engine oil, make sure that the engine main unit and engine oil are sufficiently cooled down. Otherwise, there may remain a risk of scald. Allow sufficient time after stopping engine for the engine oil to return to the oil tank to ensure accurate reading of the oil level indicator.

CAUTION: If the oil filled above the limit, it may become dirty or may catch fire with white smoke.

NOTICE: Never discard replaced engine oil in garbage, ground or sewage. Disposal of oil is regulated by law. In disposal, always follow the relevant laws and regulations. For any points remaining unknown, contact Authorized Service Agent.

NOTICE: Oil will deteriorate even when it is kept unused. Perform inspection and replacement at regular intervals (replace with new oil every 6 months).

Deteriorated engine oil shortens the life of the sliding and rotating parts to a great extent. Be sure to check the period and quantity of replacement.

Interval of replacement

After first 20 operating hours, followed by every 50 operating hours

Recommended oil

- API grade SF class or higher, SAE 10W-30 oil (automobile 4-stroke engine oil)

Oil replacement procedure

Change the oil as follows:

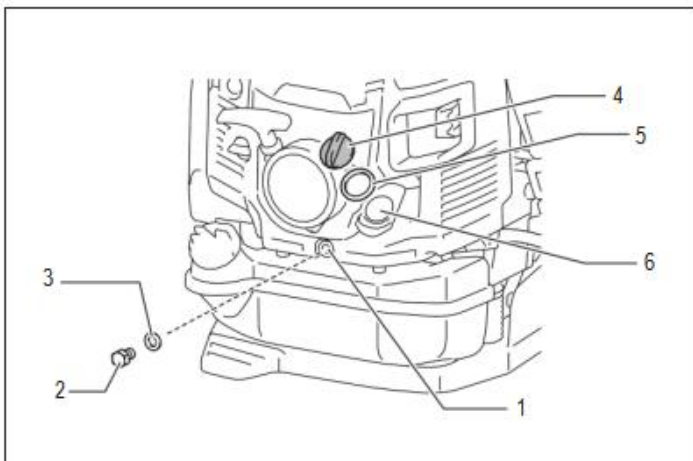

1. Drainage hole
2. Oil drain bolt
3. Gasket (Iron washer)
4. Oil cap
5. Oil cap gasket
6. Oil port

1. Put the blower down on a level surface.
2. Put a waste oil container under the drainage hole to catch the oil as it drains out. The container should have a capacity of at least 220 ml (7.4 fl oz) to catch all of the oil.
3. Loosen the oil drain bolt to let the oil drain out. Be careful not to allow oil to get on the fuel tank or other parts.

NOTICE: Be careful not to lose the gasket. Put the oil drain bolt in a location where it does not get dirt.

4. Remove the oil cap. (Removing the oil cap allows the oil to drain easily.)

NOTICE: Be sure to set the oil cap down in a location where it does not get dirt.

5. As the level of the oil being drained decreases, tilt the blower over on to the side with the drain so that the oil will completely drain out.

6. After the oil has completely drained out, tighten the oil drain bolt securely. If the bolt is not tightly fastened, it may result in oil leakage.

NOTICE: Do not forget to put the gasket back on when reattaching the drain plug

7. Pour approximately 220 ml (7.4 fl oz) oil into the oil refill port up to the upper limit of the oil gauge.

8. After filling with oil, tighten the oil cap securely to prevent oil leaks.

NOTICE: Do not forget to put the oil cap gasket back on when reattaching the oil cap.

Cleaning of air cleaner

▲WARNING: INFLAMMABLES STRICTLY PROHIBITED

Interval of Cleaning and Inspection Daily (every 10 operating hours)

Cleaning procedure

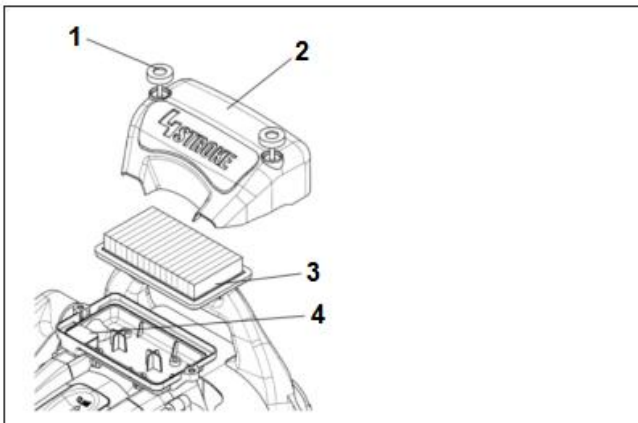

1. Knob bolts
2. Air cleaner cover
3. Filter
4. Breather

1. Loosen the knob bolts.
2. Remove the air cleaner cover.
3. Remove the filter, clean off any dirt from the filter with a cloth or air blow. Replace the filter with a new one if it is damaged or very dirty.

NOTE: The filter is a dry type and should not get wet. Never wash with water.

4. Wipe off any oil around the breather with a rag or cloth.
5. Install the element in the air cleaner case.
6. Attach the air cleaner cover and tighten the knob bolts.

NOTICE: Clean the filter several times a day, if excessive dust adheres to it due to dusty environment.

NOTICE: If operation continues with the filter remaining not cleared of oil, oil in the air cleaner may fall outside, resulting in oil contamination.

Checking the spark plug

▲CAUTION: Do not touch the spark plug while the engine is running. Otherwise electrical shock may result.

▲CAUTION: Set the stop control lever/stop switch to OFF "O" position.

▲ CAUTION: Check the spark plug cord regularly. If it is damaged or torn, replace it. Otherwise electrical shock may result.

NOTICE: When removing the spark plug, clean the spark plug and cylinder head first, so that no dirt, sand, etc will enter the cylinder.

NOTICE: Remove the spark plug after the engine has cooled down in order to avoid damaging the threaded hole in the cylinder.

NOTICE: Install the spark plug properly into the threaded hole. If installed at an angle, the threaded hole in the cylinder will get damaged.

1. To open the plug cover, pull it.

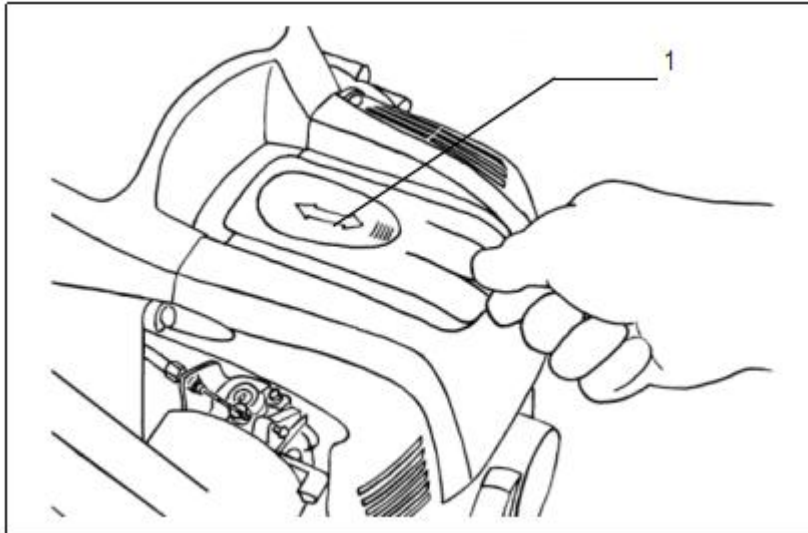

► 1. Plug cover

2. Use the box wrench provided as a standard accessory to remove and install the spark plug.

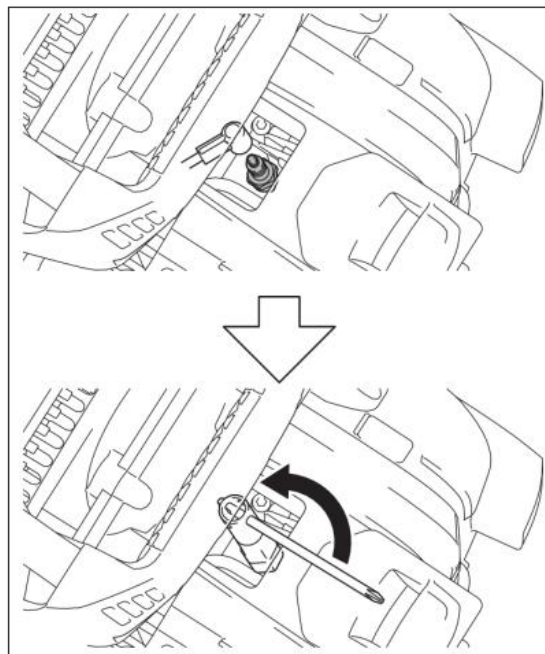

3. The appropriate clearance between two electrodes of spark plug is 0.7 to 0.8 mm (0.028" to 0.031"). Adjust to the correct clearance when it is too wide or too narrow.

Clean thoroughly or replace the spark plug if it has accumulated carbon or contaminated.

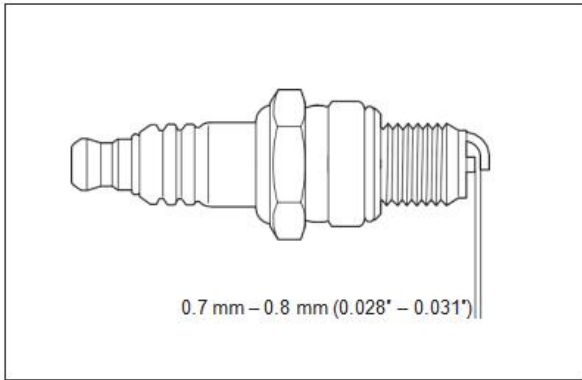

Cleaning the fuel filter

CAUTION: Make sure there is no damage on the fuel tank. If there is any damage on the fuel tank, ask authorized service center immediately for repair.

NOTICE: Clean the fuel filter regularly. Clogged fuel filter may cause difficulty of start-up or failure of engine speed increase.

Check the fuel filter regularly as follows:

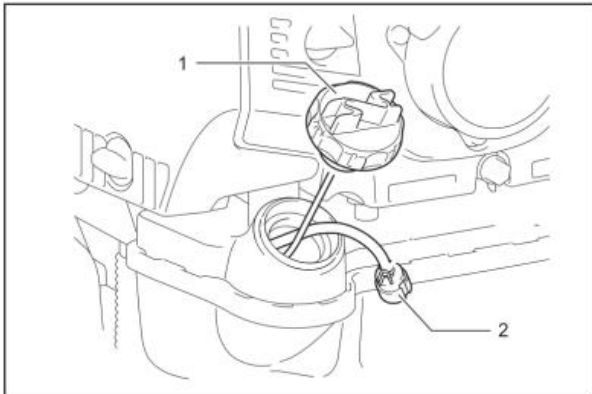

► 1. Fuel tank cap 2. Fuel filter

1. Remove the fuel tank cap, drain the fuel to empty the tank. Check the tank inside for any foreign materials. If any, wipe clean such materials.
2. Pull out the fuel filter with wire through the fuel filling port.
3. If the fuel filter surface is contaminated, clean it with gasoline.

NOTICE: Follow the method specified by each local authority for disposing the gasoline used for cleaning the fuel filter.

NOTICE: Replace the fuel filter if it is excessively contaminated.

After checking, cleaning or replacing, insert the fuel filter into the fuel pipe and fix it with the hose clamp. Reset the fuel filter in the fuel tank and tighten firmly the fuel tank cap.

Inspecting bolts, nuts and screws and other parts

Retighten loose bolts, nuts, etc. Check for fuel and oil leakage.

Replace damaged parts with new ones for safety operation.

Cleaning engine, cooling air inlet

Cleaning engine, cooling air inlet

Keep engine clean by wiping down with a cloth rag.

Keep the cylinder fins free of dust or dirt. Dust or dirt adhering to the fins may cause engine overheat and piston seizure.

Blowing air is taken in from the air inlet vent. When airflow drops down during operation, stop engine and inspect the air inlet vent for any blockages. Clean it if necessary. Such a blockage may cause overheat and damage the engine.

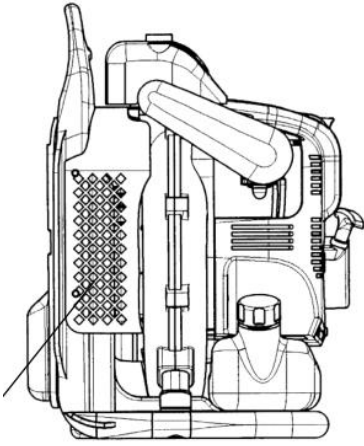

Others maintenance

Any maintenance of adjustment work that is not included and described in this manual is only to be performed by Authorized Service Agent.

Storage

▲ WARNING: When draining the fuel, stop the engine and wait for the engine to cool down. Failure to do so may cause burns or fire.

▲ CAUTION: When you store the machine for a long time, drain all fuel from the fuel tank and carburetor, and keep it at a dry and clean place.

Drain fuel from the fuel tank and carburetor before storing the machine as follows:

1. Remove the fuel tank cap, and drain fuel completely. If there is any foreign materials remaining in the fuel tank, remove it completely.
2. Pull out the fuel filter from the refill port using a wire.
3. Push the primer pump until fuel is drained from there, and drain fuel coming into the fuel tank.
4. Reset the filter to the fuel tank, and securely tighten the fuel tank cap.
5. Then, continue to operate the engine until it stops.
6. Remove the spark plug, and drip several drops of engine oil through the spark plug hole.
7. Gently pull the starter handle so that engine oil will spread over the engine, and attach the spark plug.
8. Keep the machine with its carry handle upside.
9. Keep the drained fuel in a special container in a well-ventilated shade

8. DECLARATION OF CONFORMITY



BUILDER SAS

ZI, 32 rue Aristide Bergès – 31270 Cugnaux - France

Tel: +33 (0)5.34.502.502 Fax: +33 (0)5.34.502.503

Declares that the machines:

PETROL BLOWER

Model: FSĐT75

Serial No.: 20231256041-20231256190

The people name holding the technical file: M. Olivier Patriarca

Have been designed in compliance with the following standards:

EN15503:2009/A2:2015

ENS ISO 14982:2009

And in accordance with the following directives:

Directive Machine 2006/42/EC

EMC directive 2014/30/EU

Emission directive 2016/1628/EU

Noise directive 2000/14/CE Annexe V & Directive 2005/88/CE

Cugnaux, 24/10/2023

A handwritten signature in black ink, appearing to read 'Philippe MARIE', is written over a light blue rectangular background.

Philippe MARIE / PDG

9. WARRANTY



WARRANTY

The manufacturer guarantees the product against defects in material and workmanship for a period of 2 years from the date of the original purchase. The warranty only applies if the product is for household use. The warranty does not cover breakdowns due to normal wear and tear.

The manufacturer agrees to replace parts identified as defective by the designated distributor. The manufacturer does not accept responsibility for the replacement of the machine, in whole or in part, and/or ensuing damage.

The warranty does not cover breakdowns due to:

- insufficient maintenance.
- abnormal assembly, adjustment or operations of the product.
- parts subject to normal wear and tear.

The warranty does not extend to:

- shipping and packaging costs.
- using the tool for a purpose other than that for which it was designed.
- the use and maintenance of the machine done in a manner not described in the user manual.

Due to our policy of continuous product improvement, we reserve the right to alter or change specifications without notice. Consequently, the product may be different from the information contained therein, but a modification will be undertaken without notice if it is recognized as an improvement of the preceding characteristic.

READ THE MANUAL CAREFULLY BEFORE USING THE MACHINE.

When ordering spare parts, please indicate the part number or code, you can find this in the spare parts list in this manual. Keep the purchase receipt; without it, the warranty is invalid. To help you with your product, we invite you to contact us by phone or via our website:

- **+33 (0)9.70.75.30.30**
- **<https://services.swap-europe.com/contact>**

You must create a "ticket" via the web platform.

- Register or create your account.
- Indicate the reference of the tool.
- Choose the subject of your request.
- Describe your problem.
- Attach these files: invoice or sales receipt, photo of the identification plate (serial number), photo of the part you need (for example: pins on the transformer plug which are broken).



10. PRODUCT FAILURE

WHAT TO DO IF MY MACHINE BREAKS DOWN?

If you bought your product in a store:

- a) Empty the fuel tank if your product has one.
- b) Make sure that your machine is complete with all accessories supplied, and clean! If this is not the case, the repairer will refuse the machine.

Go to the store with the complete machine and with the receipt or invoice.

If you bought your product on a website:

- a) Empty the fuel tank if your product has one.
- b) Make sure that your machine is complete with all accessories supplied, and clean! If this is not the case, the repairer will refuse the machine.
- c) Create a SWAP-Europe service ticket on the site: <https://services.swap-europe.com> When making the request on SWAP-Europe, you must attach the invoice and the photo of the nameplate (serial number).
- d) Contact the repair station to make sure it is available before dropping of the machine.

Go to the repair station with the complete machine packed, accompanied by the purchase invoice and the station support sheet downloadable after the service request is completed on the SWAP-Europe site

For machines with engine failure from manufacturers BRIGGS & STRATTON, HONDA and RATO, please refer to the following instructions.

Repairs will be done by approved engine manufacturers of these manufacturers, see their site:

- <http://www.briggsandstratton.com/eu/fr>
- <http://www.honda-engines-eu.com/fr/service-network-page;jsessionid=5EE8456CF39CD572AA2AEEDFD290CDAE>
- <https://www.rato-europe.com/it/service-network>

Please keep your original packaging to allow for after-sales service returns or pack your machine with a similar cardboard box of the same dimensions.

For any question concerning our after-sales service you can make a request on our website <https://services.swap-europe.com>

Our hotline remains available at +33 (9) 70 75 30 30.



11. WARRANTY EXCLUSIONS

THE WARRANTY DOES NOT COVER:

- Start-up and setting up of the product.
- Damage resulting from normal wear and tear of the product.
- Damage resulting from improper use of the product.
- Damage resulting from assembly or start-up not in accordance with the user manual.
- Breakdowns related to carburetion beyond 90 days and fouling of carburetors.
- Periodic and standard maintenance events.
- Actions of modification and dismantling that directly void the warranty.
- Products whose original authentication marking (brand, serial number) has been degraded, altered or withdrawn.
- Replacement of consumables.
- The use of non-original parts.
- Breakage of parts following impacts or projections.
- Accessories breakdowns.
- Defects and their consequences linked to any external cause.
- Loss of components and loss due to insufficient screwing.
- Cutting components and any damage related to the loosening of parts.
- Overload or overheating.
- Poor power supply quality: faulty voltage, voltage error, etc.
- Damages resulting from the deprivation of enjoyment of the product during the time necessary for repairs and more generally the costs related to the immobilization of the product.
- The costs of a second opinion established by a third party following an estimate by a SWAP-Europe repair station
- The use of a product which would show a defect or a breakage which was not the subject of an immediate report and/or repair with the services of SWAP-Europe.
- Deterioration linked to transport and storage*.
- Launchers beyond 90 days.
- Oil, petrol, grease.
- Damages related to the use of non-compliant fuels or lubricants.

* In accordance with transport legislation, damage related to transport must be declared to carriers within 48 hours maximum after observation by registered letter with acknowledgement of receipt.

This document is a supplement to your notice, a non-exhaustive list.

Attention: all orders must be checked in the presence of the delivery person. In case of refusal by the delivery person, it you must simply refuse the delivery and notify your refusal.

Reminder: the reserves do not exclude the notification by registered letter with acknowledgement within 72 hours.

Information:

Thermal devices must be wintered each season (service available on the SWAP-Europe site). Batteries must be charged before being stored.



BUILDER SAS

32 rue Aristide Bergès - Z.I. du Casque - 31270 Cugnaux - France

Made in PRC 2023